



Volume 8, Issue 10  
Dec., 2008

Welcome to www.CubRoundtable.com  
RT Newsletter

Webelos activity badges Craftsman and Scientist

**Theme: Holiday Lights**

**December: Holiday Lights**

**Tigers – Ach at Den Meeting 3D, 5G –  
Ach at Home 1F, 2F – Elect. 1, 2, 8, 10 or 12,  
11**

**Wolf - Ach at Den Meeting 2A, 8A, 8D, 11B  
Ach at Home 11A-D, 8 B-E – Elect. 9, 13, 17**

**Bear – Ach at Den Meeting– 3F, 9A, 9D, 15B  
Ach at Home 2, 6E, 9C, 10A – Elect. 9A,11**

**PRE OPENING ACTIVITIES**

*Christmas Wishes*

Find the correct path through the maze.

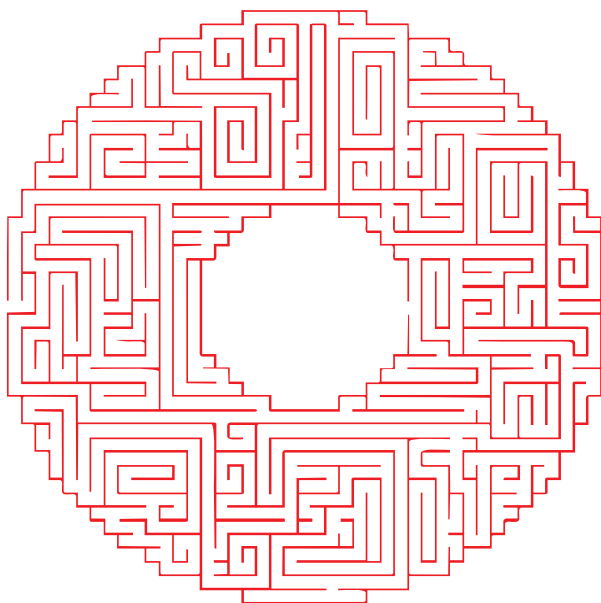

**Thanks for all the cards and notes  
from you all!**

**HOLIDAYS**

E Y N V I M S M X S H D A U S  
 Y E L R I I O S I E O A B N N  
 E K R I S S N M S N M D O C F  
 K D K T M I I L V O E W S L P  
 R S E I S A L T B C M S T E R  
 U R T U E A F E S E P M A S E  
 T P O O B W M L N N Y O E N S  
 K C B W C C S T T I F T R W E  
 B W O N S K A D S P A S T R N  
 C N T E P M I N N I W U D E T  
 S C H U R C H N D E R C N A S  
 L L I W D O O G G L I H E T S  
 P D B R O T H E R S E R C H S  
 F I R E P L A C E X M S F S M  
 G N I G N I S S T H G I L B M

**WORDS FOR THE HOLIDAYS**

- |                |           |            |           |
|----------------|-----------|------------|-----------|
| AUNTS          | DAD       | MOM        | SNOWMEN   |
| BROTHER        | FAMILY    | PINE CONES | STOCKINGS |
| CANDLES        | FIREPLACE | PRESENTS   | TREATS    |
| LIGHTS         | FRIENDS   | SINGING    | TURKEY    |
| CHURCH         | GOODWILL  | SISTER     | UNCLES    |
| COUSINS        | HOME      | SNOW       | VISITS    |
| CHRISTMAS TREE | SNOWBALLS | WREATHS    | CUSTOMS   |

**The Holidays are family and friends and what you do  
with the season Make is a Great One!**

**Answer to Christmas Wishes**

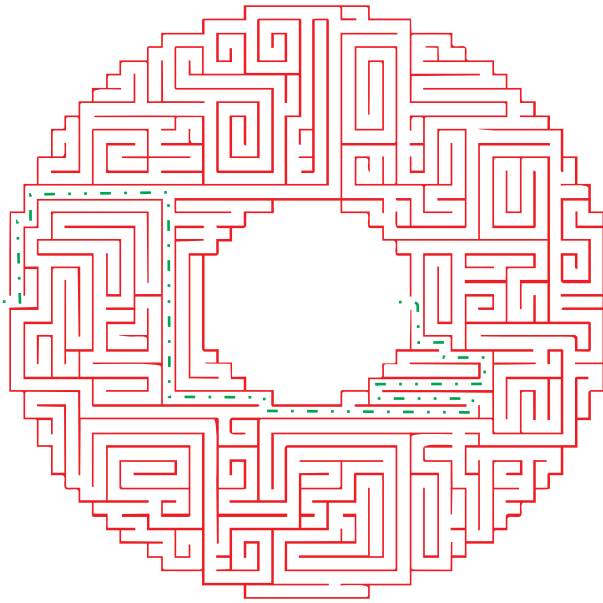

**ANSWER TO HOLIDAYS**

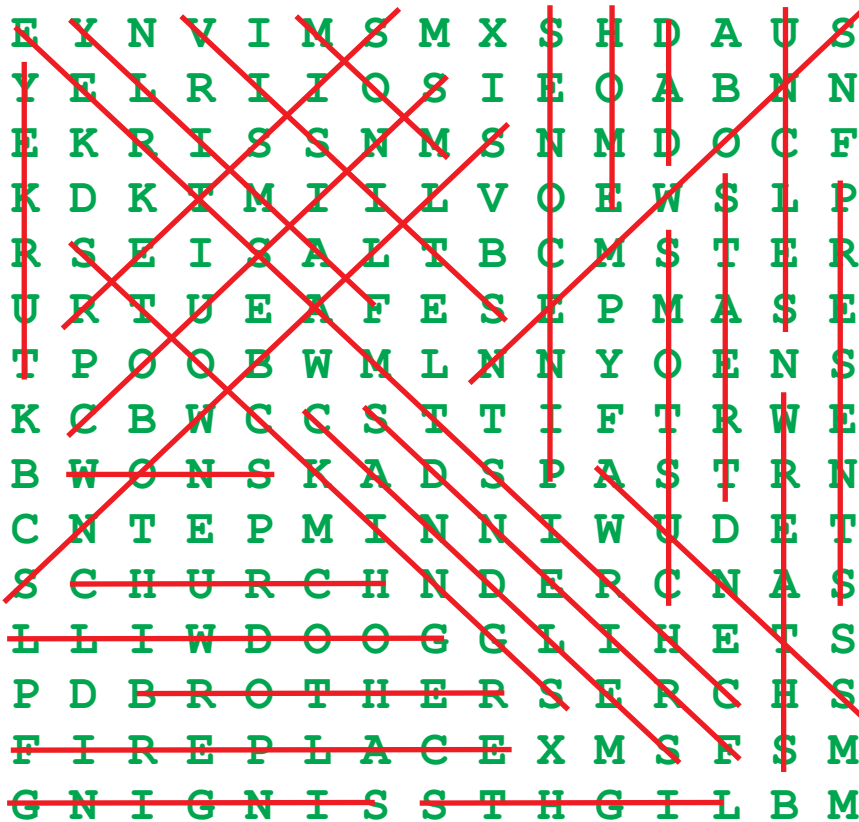

I want to thank all the Cub RT Commissioners who sent notes supporting my family through a very rough time the last couple of months. My father died unexpectedly at the end of Aug. while we were coming back from taking Sara to college in Florida. the trip was crazy with Fay down there but we were able to miss

most of the rain and wind. It gave us a healthy respect for the weather and to be prepared. Mobile homes and trailers are NOT were you want to be in bad weather. Many folks in the areas we traveled through we're hit really bad, between the wind and the high water. It brought back memories of the flood a year ago up here in Findlay, OH.

This season we have something to be thankful for, no matter what it maybe. Gather friends and family together and share that you care for them.

Maybe someone lost a home but family pulls together and helps them overcome the hard times. It is said that we grow from adversity so what have we learned. Things come and go but family and friends can help lift you up if you open up to them. After having 2 deaths on top of each other, I caught the flu bug and wondered if I would every get caught up. The CSRT commissioners who get this newsletter wrote that they would make it though until I got back on my feet, that family comes first at times like this. Not only do we have our family but we have an extended family in Scouting no matter where we go. At present I have been working to bring Scouting to the Japanese families here in Northwest Ohio and it is a challenge but one I think will be worth the work.

Also another idea that hit me for my University of Scouting doctoral degree in Venturing is that I am working on ways for Venturing crews to show what they learned to Cub Leaders and Cub Scouts. Would anyone like a copy to look over or use in their areas to tap into a great resource for scouting? I have taken the Cub program levels and listed what Cub Scouts need to learn for advancement with hopes that the Venturing crews could learn how to teach it to the Cub scouts. Send me an e-mail at [CubRT@woh.rr.com](mailto:CubRT@woh.rr.com) and I'll get back with you.

**This issue is mostly from Heart of America Council including past years. Thanks.**



## GATHERING ACTIVITIES

Give first timers a special name tag so they are easily recognized. Name tags for returning participants may be shaped like a candle or holiday light bulb. Have the participants play Holiday Bingo.

### GATHERING ACTIVITIES

#### Holiday Bingo

By Heart of America Council

**Materials:** Bingo cards with a grid of 20 (five by five) squares, pencils.

As people arrive, give each person a bingo card and a pencil. Participants are directed to introduce themselves to others and ask the person they meet to fill in something that is related to the holiday season in one of the boxes on their cards. Examples include snow, candy canes, candles, family and greeting cards.

First one to get a row wins. (Card on page 4)

**To design your own Bingo cards** go to-  
<http://print-bingo.com/g.php?gs>

### OPENINGS

#### Spirit of Cub Scouting

**Materials:** one blue candle for Cub 1, one white candle for each of the remaining Cub Scouts. (If it is not possible to use candles in your meeting room, use artificial candles or drawings of candles.)

**Arrangement:** The room light is dimmed. A den of boys stands in front holding lit candles. One boy holds an unlit blue candle. Narrator stands away from boys.

**Narrator:** This is a season of lights. It is the time when the days are shorter and the nights are long. But somehow things seem brighter. Shopping centers are bright with Christmas lights. Thousands of homes burn candles to light the way for the Christ Child. Thousands more burn candles to commemorate the miracle of the oils of Hanukkah. And thousands yet will light candles of Kwanzaa. Even the stars in the winter sky seem brighter. Each of those candles also represents the spirit of goodwill among humanity. (Cub 1 lights blue candle.)

**Narrator:** But the most brilliant glow comes from spirit of goodwill that you live year-round in the Cub Scout Promise and the Law of the Pack. This candle represents that spirit.

**Cub Scouts:** Please stand and repeat the Cub

Scout Promise and the Law of the Pack.

**Narrator:** We will leave our Cub Scout spirit candle burning throughout this meeting to remind ourselves of our ideals.

#### Holiday Lights

**Personnel:** Narrator, den leader, seven Cub Scouts.

**Equipment:** Recording of a holiday song; U.S. Flag (Play the recording softly during the ceremony)

**Narrator:** I pledge allegiance . . .

**Cub 1:** . . . at this joyous time of year,

**Narrator:** to the flag . . .

**Cub 2:** . . . a symbol of unity, just as Christmas, Hanukkah, and Kwanzaa are symbols of peace,

**Narrator:** of the United States of America . . .

**Cub 3:** . . . a land we love,

**Narrator:** and to the republic for which it stands . . .

**Cub 4:** . . . the people who live in and stand up for our wonderful country,

**Narrator:** one nation under God . . .

**Cub 5:** . . . Who blessed our people,

**Narrator:** indivisible . . .

**Cub 6:** . . . a nation united through love,

**Narrator:** with liberty and justice for all . . .

**Cub 7:** . . . a land where we all have equal rights.

**Narrator:** Please stand as the United States flag is brought forward. (Pause until flag is posted.)

Please join our den in the Pledge of Allegiance.

#### Golden Rule

**Personnel:** Cubmaster and a Den

**Equipment:** A large Golden Rule, flashlights, and a large poster with the Cub Scout Promise on it, a long wooden dowel with a black arrow point. As an added special effect, you could tape them up at the 12" of the rule.

**Cubmaster:** What is the golden rule? Do unto others as you would have them do unto you! Do we always do that? I'm afraid not! Sometime we hit the other guy, or talk about him behind his back, or fail to help him when he needs our help. We're not doing to him as we would like to do to us. Where do you stand on the "Golden Rule? Do you almost never think about other people and their feelings? Then you're here on the golden rule. (Point to the 2" mark on the rule) Most of us, I think are here, because sometimes—but not always—we remember the other guy (point to the 6" mark). As good scouts, we should always aim to go as far as we can on the golden rule. We won't make it all the way to the end, because "nobody's perfect", but if we try real hard, we can make it to here (point

# Holiday Bingo

B

I

N

G

O



to the 11" mark). Let us renew our pledge to follow the golden rule by repeating the Cub Scout Promise.

**Den # \_\_\_\_** : Would you please repeat after us, and please repeat the Pledge.

(Note: There are Cubs and adults that do not know, or forgot the Pledge. You may want to have a copy of the Pledge up front. You can also modify the verbiage, or have each of the boys point to the parts on the ruler.)

### AUDIENCE PARTICIPATION

#### Here Comes Santa

Divide the audience into five groups. Assign each group a part of the story to perform when the designated word is read in the story.

**SANTA** – Ho, ho, ho!

**GIFTS** – Wow!

**SLEIGH** – Sssssssss!

**GOOD LITTLE BOYS** – Yea!

**GOOD LITTLE GIRLS** – Ooooooooooh!

All year long, **SANTA** and his elves have been working, making **GIFTS** for good little boys and good little girls. Now it's time to jump into his **SLEIGH** and deliver on his promise.

While all the **GOOD LITTLE BOYS** and **GOOD LITTLE GIRLS** are sleeping, **SANTA** loads his **SLEIGH** with **GIFTS** and takes off.

Soon, **SANTA** and his **SLEIGH** arrive on the roof of a house. Down the chimney he goes. He fills the stockings full of **GIFTS** **GOOD LITTLE BOYS** and **GOOD LITTLE GIRLS**. Back up the chimney he goes and jumps into his **SLEIGH**.

Off rides **SANTA** again, driving his **SLEIGH** full of **GIFTS** for **GOOD LITTLE BOYS** and **GOOD LITTLE GIRLS**. But what's this? He's making a detour. Here comes **SANTA** to Pack (pack number)!

#### The House Where Santa Claus Lives

Here is a group participation story that will brighten up your Christmas pack meeting. Start by singing carols and other holiday songs. For your final song, sing "Santa's Coming". As the song ends, Santa Claus enters from the rear, calls "Merry Christmas," and throws small candies to the audience.

When Santa reaches the front of the room, he tells this story.

"Old Santa has traveled many a mile to be with you. He has been impressed with the preparations for Christmas and has looked into all your homes. Tonight Santa would like to tell you about a house you have never seen. It is the house where Santa Claus lives.

While telling the story, Santa will need help for certain words. Every time those words are spoken, I want you to make certain signs. Let's all practice them before we start the story.

**HOUSE** – hands over head in inverted V

**SHED** – hands in front of chest in inverted V

**SLED** – hands together as in praying waving from the left to the right

**REINDEER** – one hand, palm forward, at each side of the head, thumbs touching temples.

**PACK** – both hands over shoulder as if carrying load

**LITTLE GIRLS** – all girls (young and old) stand up

**LITTLE BOYS** – all boys (young and old stand up

**BOX** – show dimensions with hands

**LION** -- growl

**DOLL** – both hands as if praying at side of head, head slightly bent

**SOLDIER** – give Cub Scout salute while at attention

**TRAIN** – pump arm in circular motion

**SANTA CLAUS** – pat stomach with both hands and say "Ho, Ho!"

Now let's begin our story. (Santa reads or gives story from memory, and make gestures)

This is the **HOUSE** where **SANTA CLAUS** lives. This is the **SHED** behind the b where **SANTA CLAUS** lives. This is the **SLED** that is kept in the **SHED** behind the **HOUSE** where **SANTA CLAUS** lives.

These are the **REINDEER** that pull the **SLED** that is kept in the **SHED** behind the **HOUSE** where **SANTA CLAUS** lives. This is old **SANTA CLAUS** who guides the **REINDEER** that pull the **SLED** that is kept in the **SHED** behind the **HOUSE** where **SANTA CLAUS** lives.

This is the **BOX** that is in the **PACK** all filled with toys for good **LITTLE GIRLS** and good **LITTLE BOYS** that is carried by old **SANTA CLAUS** who guides the **REINDEER** that pull the **SLED** that is kept in the **SHED** that is behind the **HOUSE** where **SANTA CLAUS** lives.

This is the **LION** that frightened the **DOLL** that is in the **BOX** that is in the **PACK** all filled

with toys for good **LITTLE GIRLS** and good **LITTLE BOYS** that is carried by old **SANTA CLAUS** who guides the **REINDEER** that pull the **SLED** that is kept in the **SHED** that is behind the **HOUSE** where **SANTA CLAUS** lives.

This is the **SOLDIER** that shot the **LION** that frightened the **DOLL** that is in the **BOX** that is in the **PACK** all filled with toys for good **LITTLE GIRLS** and good **LITTLE BOYS** that is carried by old **SANTA CLAUS** who guides the **REINDEER** that pull the **SLED** that is kept in the **SHED** that is behind the **HOUSE** where **SANTA CLAUS** lives.

This is the **TRAIN** that runs on a track and carried the **SOLDIER** forward and back, who shot the **LION** that frightened the **DOLL** that was in the **BOX** that was in the **PACK** all filled with toys for good **LITTLE GIRLS** and good **LITTLE BOYS** that was carried by old **SANTA CLAUS** who guides the **REINDEER** that pull the **SLED** that is kept in the **SHED** that is behind the **HOUSE** where **SANTA CLAUS** lives.

Now old santa must be on his way. He has one parting thought for you parents. Work hard at Cub Scouting with your sons, and it will be like Christmas every day of the year.

Merry Christmas to all!

### **APPLAUSES, CHEERS,**

#### **Cub Scouts Give Goodwill**

Divide the audience into three groups. The first group says, "Cub Scouts", the second group says, "Give", and the third group says, "Goodwill". Cubmaster points to groups randomly. Conclude the cheer by pointing to groups in the correct order.

#### **Santa Cheer**

Call out "Ho, ho, ho!" three times, the first time softly as Santa approaches, then loudly, then softly again as his sleigh flies off.

#### **Rudolph Applause**

Put thumbs to head with fingers pointing up and form antlers; wrinkle nose and say, "Blink, blink!"

#### **Santa Claus**

Reach out and hold stomach and say loudly "Ho, Ho, Ho,"

#### **Snowball**

Pick up snow, pack it into a ball, throw it and yell "Splaaaat"!

### **Skit**

#### **Solving a Christmas Problem**

**Personnel:** 8 Cub Scouts

**Equipment:** Christmas tree, chair

**Setting:** As the scene begins, a Cub Scout 6 is seated, head in hands by a Christmas tree. The other Cub Scouts enter and speak to him.

**Cub 1:** What is really wrong with you, we've got a lot of work to do.

**Cub 2:** Come on don't be so down. Your face looks terrible with that frown.

**Cub 3:** Tell us why you are so sad. At Christmas time you should be glad.

**Cub 4:** Maybe with Christmas so near, he's worrying about what he's getting this year.

**Cub 5:** Come on and let us help you out, cause helping others is part of being a Cub Scout.

**Cub 6:** (Jumps up with a big smile on his face and shakes hands and slaps on back of Cub #5) That's it! That's it! Thanks old Buddy, my thinking sure was pretty muddy!

**Cub 7:** (All look puzzled at each other.) What did he do that made things right! I guess I'm just not too bright!

**Cub 6:** (speaking with lots of expression) I don't have money to buy my Mom a gift you see, but now I know I'll give her just helpful me!

**Cub 8:** Boy I'm glad you've helped us all remember, the importance part of that holiday in December. (All put their arms around each other and walk off stage in a happy group.)

### **Season's Meanings**

**Personnel:** Reporter, Cub Scout, Neighborhood boys.

**Setting:** Street corner, (Street lamp or similar props) and microphone with radio station letters on it.

**Reporter:** Good evening listeners, this is your on the scene reporter interviewing people about what this season means to them. Here comes a Cub Scout... (Scout wanders on to stage) Excuse me son, but do you know the meaning of this season?

(Before the Scout can answer a boy walks on stage and speaks to him)

**Boy 1:** Jimmy, can you help me out? I lost my lunch money on the way to school and I didn't have any breakfast today.

**Scout:** Sure, I've done that myself ... Here's a dollar for lunch.

**Boy 1:** Thanks! (As he runs off stage)

**Reporter:** As I was saying, do you know the meaning of He is interrupted by boy 2 coming on stage)

**Boy 2:** Hi Jimmy, here's a thank you card from my mom for all your help after the flood.. We really appreciate your help with clean up and all....

**Scout:** Thank you. I was happy to help. That flood was a real mess all right.

**Reporter:** Excuse me, but I'm here doing a report on the season and what it means to people...

.What does this season mean to you.... (He is interrupted once more by boy 3)

**Boy 3:** Jimmy, how are you doing on your Christmas gift buying?

**Scout:** I'm not buying gifts this year. Instead, the boys in my Cub Scout den are going to make gifts for people in nursing homes and then give the gifts after we have sang songs to them at the Christmas party we are having. After all .... those people enjoy our putting on that party and all more than fancy gifts we could buy them .... And we enjoy it more too .... It's like we're giving a part of ourselves when we share with them like this.

**Boy 3:** That sounds neat....

**Scout:** Excuse me sir, was there something that you wanted to ask me?

**Reporter:** Well, I was going to ask you what this season meant to you?... But I can see what it means by the things you do. Merry Christmas son, and keep up the good work.

## ADVANCEMENT CEREMONIES

### Advancement Ceremony:

#### Candlelight Advancement

**Materials:** The Cub Scout spirit candle from the opening ceremony, one candle for each family whose son is receiving an award.

**Cubmaster:** This is a special season. We celebrate the birth of Christ, the light of the World; Hanukkah, the Festival of Light; and Kwanzaa. Tonight we celebrate the Light of Cub Scouting by recognizing the achievements of these boys. (Dim the lights and call names. As each family comes forward, give them a candle and have them light it from the Cub Scout spirit candle.)

**Cubmaster:** The glow from these Cub Scouts' achievements and the pride of their families light up this stage. When they leave here, that light will be spread throughout this pack and our community. Congratulations!

### Lighting the Tree

**Props:** Christmas tree strung with lights; cardboard ornaments in the shape of Cub Scout badges, arrow points, Webelos badges and activity badges; tape recorder with a holiday song tape ready to play (Note: a Hanukkah menorah or Kwanzaa candelabra can be substituted for the Christmas tree.)

**Personnel:** Cubmaster, Webelos den leaders, advancing boys and their parents

**Setting:** Leave the tree's lights unlit. Call forward advancing boys and their parents and have them stand around the tree. As you give each boy's award to his parents to pin on his uniform shirt, give the boy the appropriate cardboard ornament and ask him to hang it on the unlit tree (or place it beside the menorah or candelabra). When all boys have done so, say the following

**Cubmaster:** Over the past month, our Tiger Cubs, Cub Scouts, and Webelos Scouts have worked hard to earn these awards. Tonight they hang a symbol of their achievement on our Christmas tree (or place it by the menorah or Kwanzaa candelabra). We applaud them for their individual efforts.

**Cubmaster:** But the true light of the holidays comes when boys work together as a pack and do their best. Cub Scouts, on the count of three, everyone who did his best should yell, "We did our best!" One, two, three . . . ("We did our best!") (Dim the room lights and light the Christmas tree lights. Start the holiday song on the tape player and lead the audience in singing.)

**Cubmaster:** Thank you, Cub Scouts, families, and friends, for adding to the light of the holidays.

### Gift Wrapped Advancement

**Personnel:** Cubmaster, Cubs advancing and their parents.

**Equipment:** Gift wrap awards in holiday paper and place beneath small decorated tree (or hang as decorations on the tree) on advancement table.

**Cubmaster:** We're in the holiday season. This is a time when we give and receive gifts among our friends and families. Tonight we have some special gifts to give to some of our Cub Scouts. These gifts are special because these gifts have been earned. These gifts represent hard work on the part of these boys. The first gifts go to our newest Cub Scouts - who have earned the Bobcat badge.

(Read names and present with "gift")  
 And now, to celebrate the time and effort spent by these boys, we would like to give gifts to those who have earned their Wolf badges. (Read names and present with "gift") Next a group of boys who richly deserve this gift. They have completed requirement for their Bear badges.  
 (Read names and present with "gift")  
 Our Webelos Scouts are not forgotten. They have been working and have earned activity badges and Webelos Badges.  
 (Read names and present with "gift") We congratulate each of you! Be proud of these gifts from Scouting that you have worked hard to earn. Remember, a gift is much richer when you share it. So, please share what you have learned in Cub Scouting with others, and thank those who have helped you experience this special holiday.

**Variation:** Have a Christmas tree light bulb with the Cub Scout's name lettered on with a marking pen. Use one Blue colored bulb for Bobcats, Red for Wolf, Green for Bear, Gold for Arrow Points and White for Webelos. Cubs being given awards are called forward with their parents and screw in a bulb into a strand not plugged in. When all the awards have been presented, plug in the strand of Advancement lights. The Cub can take his bulb home after the meeting.

**Cubmaster:** These lights show how much these boys have added to our pack.

## CRAFT PROJECTS

### "Stained Glass" Greeting Card

**Materials:** Clear sheet protector; wide black permanent marker; permanent markers in various colors; aluminum foil; cardstock; tape

Fold cardstock in half. Cut a shape (oval, triangle, simple holiday shape) out from one side. Cut open the sheet protector and cut out a piece that will cover the opening in the cardstock. Using the black marker, draw thick lines on the sheet-protector piece. Let dry. Tape the sheet protector on the inside of the card against the opening. Using color markers, fill the areas between black lines. Crumple up a piece of aluminum foil, then smooth it out and tape it to the back of the sheet protector.

Write a holiday message on the inside of the card.

### Glitter Candleholder

**Materials:** Small glass jar; colored tissue paper in three or four colors; glue; fine glitter; container for blue; brush; tea candle.

Cut the tissue paper into small pieces of any shape, but not too small (one to two inches). Dilute a small amount of glue with about an equal amount of water. Mix glitter with the glue. Using the brush, spread a small amount of the glue mixture onto the jar. Stick a piece of tissue, making sure the tissue piece gets wet but not dripping. Apply another tissue piece with one edge overlapping with the first. Keep applying tissue pieces. Colors will run, blurring the edges of individual tissue pieces. When the jar is covered, apply a thin coat of the glue mixture over the tissue pieces.

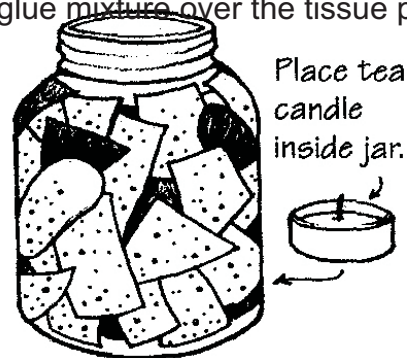

When dry, place a tea candle inside the jar. Note: For fire safety, avoid gluing tissue pieces to the top edge of the jar.

### Frosty Pop

**Materials:** (for each Frosty Pop) Three marshmallows, one peppermint patty, one chocolate kiss, one bamboo skewer, one twist tie or short length of ribbon; round toothpicks; food coloring (red, orange, green, black or blue); clear plastic wrap;

Push three marshmallows onto the skewer; add peppermint patty and chocolate kiss for Frosty's hat, taking care that the skewer goes only partway into the chocolate kiss. Dip the tip of a toothpick into black or blue food coloring and gently press it into the side of the top marshmallow to make Frosty's eyes. Use food colors of your choice to draw a carrot nose, mouth and buttons. Wrap the pop in clear plastic wrap and tie it at the bottom with twist tie or a piece of ribbon.

### Star of David Plaque

**Materials:**  
 Glue  
 Aquarium gravel  
 Large plastic lid  
 Plain paper

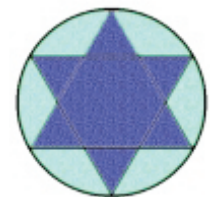

1. Trace around the plastic lid on a piece of

plain paper. Divide this circle into six sections with a compass. Connect every other mark to form a triangle. Then connect the other three marks to complete the Star of David. Lay the lid on top of the design and trace around the outline of the star with a marker.

2. Coat the whole star with white liquid glue, then cover the glue with whatever color gravel you choose. Let this star dry completely. Then coat the background with glue and carefully add a contrasting color gravel to it. When your plaque is dry, add a string hanger to the back.

**Rudolph Slide**

**Materials:**

Flat clothes pin Coping saw Sandpaper Stain or paint Glue 7 mm. Eyes Brown felt 6 mm. Bead Fine-line markers Plastic ring

1. Cut "legs" of clothes pin off with coping saw. These will not be used. Sand and stain or paint clothes pin head a light brown.
2. Turn clothes pin upside down (cutoff part becomes top of his head) Glue on eyes.
3. Trace antler pattern onto brown felt. Cut out and glue to head. Glue on bead for nose.
4. Draw mouth with marker or paint.
5. Glue plastic ring on back.



**GAMES**  
**Kris Kringle Relay**

**Equipment:** Shoe boxes or large paper bags. Boys line up in teams, relay style. Each team has two shoe boxes or large paper bags, representing Kris Kringle's boots. On signal, each player, in turn, places his feet in the 'boots' and shuffles up to and around a chair at the opposite end of the room. He shuffles back to starting point, where the next boy takes over. First team to finish wins.

**Icicle Hunt**

**Equipment:** String  
Hide icicles (strings) around the room. Boys hunt for icicles. The winner is the boy whose strings form the longest line when laid end to end, not the player who collects the most strings. Icicles should be of varying lengths, for the best results.

**Snowball Toss**

**Equipment:** Ping pong balls, Small box  
Each player needs three ping pong balls. A small box is placed in center of room. Players form a circle around the box. Going around the circle, each player tosses one ball into box as his turn comes. If the ball misses, it is returned to the player. Tossing is continued until one player has no more snowballs left. He is the winner.

**Christmas Treasure Hunt**

**Equipment:** A small red Christmas stocking, a list of objects hidden about the room, a prize.  
Some of the things that may be on the list are: unsharpened pencil, eraser, peanuts, lollipops, small toys, candy bar, etc.  
Each boy is provided with a small red Christmas stocking and is given a list of objects hidden about the room which he has to find. No boy is allowed to pick more than one of each of the objects hidden, such as those listed below. Give a prize to the one that brings back the largest number of treasures in a set amount of time. Some of the things that may be on the list are: Unsharpened pencil, eraser, peanuts, lollipops, small toys, candy bar, etc.

**CLOSING CEREMONY**

**Gifts**

**Personnel:** Leader and 8 Cubs  
**Equipment:** Gift-wrapped box or pieces of gift decorated construction paper with Cubs' lines written on its. Individual candles or flashlights.

**Setting:** The Den of Cubs line up across the front of the room with their leader on their right. As each boy speaks his part he places his gift under the Christmas tree or presents it to the Cubmaster.

**Leader:** These are gifts the Cub Scouts give:

- Cub 1:** Happiness
- Cub 2:** Cheerfulness
- Cub 3:** Honesty
- Cub 4:** Sincerity
- Cub 5:** Courtesy
- Cub 6:** Reverence
- Cub 7:** Thoughtfulness
- Cub 8:** Friendliness

**All:** (Turn down room lights and light candles or flashlights) Please join us in singing Silent Night (After song is finished)

**Happy Holidays to All!**

### Gifts

**Personnel:** Cubmaster or Den Leader

**Cubmaster:** Why not pick something from this list of Christmas

gifts which are not advertised on television?

Give your parents the words "I love You".

Give your children a full day of your time.

Give an ear to someone who needs a listener.

Give a hand to someone less strong.

Give an old friend a surprise visit or letter.

Give a former neighbor a phone call.

Give yourself time to reflect on this holy season.

### Closing: Spirit of Cub Scouting

**Materials:** The Cub Scout spirit candle from the opening ceremony

**Cub 1:** Now our meeting is ending, and we must blow out the candle of the spirit of Cub Scouting.

**Cub 2:** But let us silently pledge to keep the ideals it represents ever burning in our hearts. (Extinguish the candle.)

**Cub 1 and 2:** Goodnight, everyone. Happy Holidays!

### CUBMASTER'S MINUTE

#### Cub Scout Heart

The heart of a Cub Scout is a beautiful and shining thing. It can light up the darkest night. It can bring a smile to the face of other people. Why? Because the heart of a Cub Scout is bright with the Cub Scout spirit, the spirit that says, "I will help those around me. I will give of myself to those who need my help." Your will give off the special glow of kindness and brotherhood that will shine forever around you.

### WEBELOS

Craftsman

#### Camp Locker

These dimensions are arbitrary to get the approximate size of the store bought variety, and can be changed to suit material on hand. The two pieces of 5/8" plywood don't even have to be plywood, but any type of wood you have on hand. A challenge to the leader is to calculate how many camp lockers can be made from the least amount of wood. The main problem with projects like this is not enough tools or adults to go around, so it is a good idea to have plenty moms, dads, and screwdrivers to go around.

**Materials:**

2 pieces 5/8" Plywood 13" x 11"

2 pieces 1/8" Plywood 24" x 11"

2 pieces 1/8" Plywood 24" x 13 1/2"

2 Hinges

2 pieces Rope 3 1/2' long

1 Latch

2 pieces 1/2" thin wall aluminum or plastic pipe 5" long

4 pieces 1" x 2" 22 1/2" long

Wood glue

Drywall screws

Security screws

1. For the framework drill 2 holes through the ends of the 5/8" plywood into the four pieces of 1 x 2's as shown.

2. After all 16 holes are drilled, apply glue to ends of 1 x 2's and screw to 5/8" plywood with 1 1/2" long drywall screws. Wipe off excess glue. Set aside to dry. It will need at least 1 day.

3. After the frame has dried, sit it on a table, lay bottom piece (24" x 13 1/2") on top of frame, square it up and drill 2 holes through it into either of the 1 x 2's or 5/8" plywood. Screw in loosely 2 3/4" drywall screws.

4. Finish drilling around the bottom. Remember this piece of wood is the bottom, so it needs lots of screws, 1 every 3 or 4 inches. After the bottom is drilled, remove 2 screws and glue liberally where the bottom contacts 5/8" plywood or 1 x 2's. Screw the bottom on, turn right side up, and wipe off excess glue. Do front and rear (the two 24" x 11" pieces) one at a time in a similar manner to bottom, only using 1 screw every 6 inches. Be sure to wipe off excess glue. Set aside to dry.

5. Add hinges and a latch. Go to one of the larger, more complete hardware store to get screws which need a special screwdriver to fasten

(you must buy the screwdriver, or a bit to fit the screws that fits into a cordless screwdriver) or the type of screws that are used to fasten public bathroom partitions together. Warning: This last type cannot readily be removed, so use them carefully. After construction, sand and smooth.

6. Pull rope through the conduit or pipe, knot with a loop of 2" diameter next to pipe on either side, run remainder through 1/2" holes drilled in sides, 2" down from the top, and knot inside box.

You may want to tape handles (**aluminum turns skin black**) and stain and varnish the box.

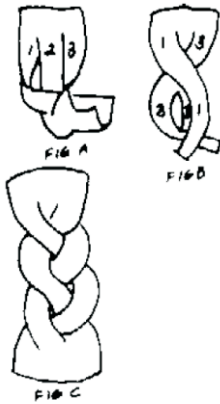
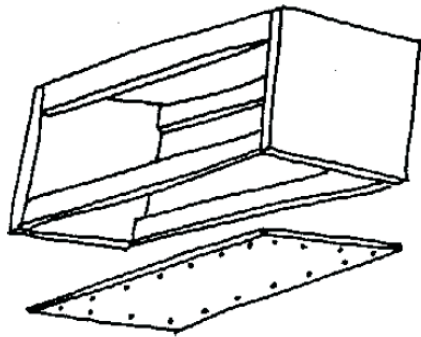
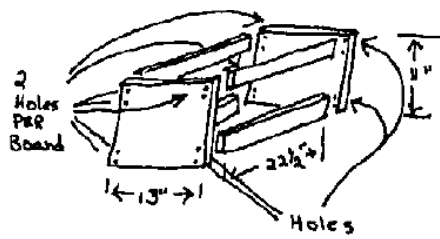

**Magic Braided**

**Materials:**

- 1 3/8" x 4 3/8" piece of fabric backed vinyl or soft leather
  - Stapler
  - Knife
1. Cut leather or vinyl using pattern.
  2. Grasp left bottom corner and push it through slit between 2 and 3 (Fig. a).
  3. Put strip 3 on top of strip 2, then put strip 1 on top of strip 3, making a sandwich with strip 3 in the middle. Work strip 3 out to left, exposing an open loop (Fig.b).
  4. Take bottom end, bring it toward you, then insert it through loop and pull it through.
  5. Rework with fingers into a braided strip which looks like Figure C.
  6. Use a small stapler to staple top and bottom ends together.

**Webelos Scientist**

**A Real Attention Getter**

**Materials:**

- Balloon
  - Plastic tape
  - Pin
- Inflate a balloon and affix 3 - 4 squares of plastic tape to it. Have a boy stick a pin through the center of each piece of tape. To everyone's amazement, the balloon will not burst. When the pins are removed the balloon still will not burst.

**What is happening:**

The adhesive substance on the tape acts like a self-sealing automobile tire, adhering to the pin as it is pressed inward. When the pin is removed, the adhesive is forced outward by the air pressure from within the balloon, automatically sealing the tiny pinholes.

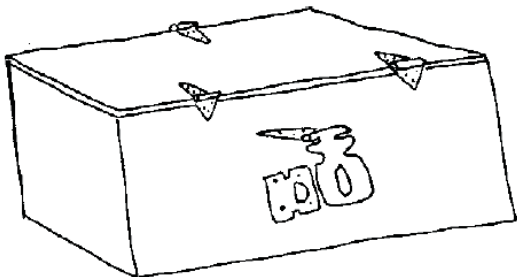

Square Head



Star or Hex Head



Security Screw

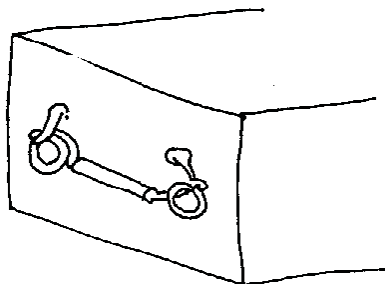

**Auto Gyro**

**Materials:**

- Paper 3 1/2 " wide by 8 1/4" long

The principle of the Auto Gyro can be easily demonstrated by making one as shown in the sketch. 1. Cut from a piece of paper 3 1/2" wide by 8 1/4" long, cutting down the center of the paper 4" and then folding the cut section to opposite sides as shown, to form the two wings.

2. Fold the balance in half, and then make two triangular folds to the midline and your Auto Gyro is ready.

3. Make two other Auto Gyros basically the same as the first one, but cut the wing area to three inches on the second one and to two inches on the third one. Try flying from the same height and observe how each model reacts. Does any thing seem to slow their descent? What actually makes it spin? Note the order in which the three models reached the ground. Are wing size, air resistance, and rate of descent related?

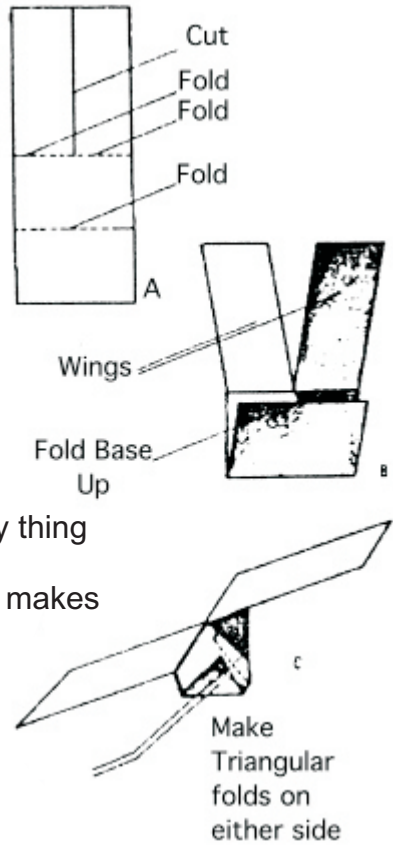

**Spinner Scope**

**Materials:**

- Paper plates
  - Scissors
  - Watercolor markers
  - Pushpin
  - Unsharpened pencil with eraser top
1. Cut out notches around edge of plates as shown.
  2. Draw a design on each plate with markers. Draw a spiral, small circles close to each other, or a simple object, such as a fish.
  3. Poke pushpin through center of plate, then into eraser end of pencil.
  4. Stand in front of mirror. Spin pencil between hands as you peer through the notches. Each design will produce a different optical illusion as the spinning elements appear to merge.

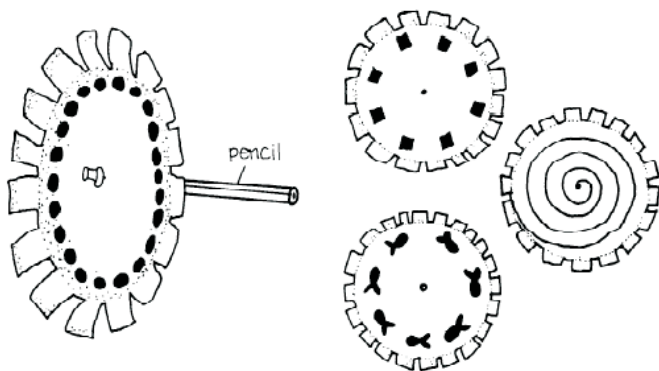

**WEB SITES**

These sites are current as of 11-07-08

<http://www.holidays.net/>

<http://www.marthastewart.com/holidays?Inc=c479cf380e1dd010VgnVCM1000005b09a00aR CRD>

[http://www.marthastewart.com/christmasworkshop?Inc=fcb5d918a92ee010VgnVCM1000003d370a0aR CRD&rsc=leftnav\\_holiday\\_halloween-decorations](http://www.marthastewart.com/christmasworkshop?Inc=fcb5d918a92ee010VgnVCM1000003d370a0aR CRD&rsc=leftnav_holiday_halloween-decorations)

<http://holidays.kaboose.com/index.html>

<http://www.hersheys.com/holidays/crafts/>

<http://www.jewfaq.org/holiday0.htm>

[http://www.chabad.org/holidays/shavuot/default\\_cdo/jewish/Shavuot.htm](http://www.chabad.org/holidays/shavuot/default_cdo/jewish/Shavuot.htm)

<http://www.santaland.com/>

<http://familyfun.go.com/holidays/>

<http://www.usa.gov/citizens/holidays.shtml>

<http://www.coloring.ws/holidays.htm>

<http://www.history.com/minisites/christmas>

<http://www.merry-christmas.com/>

<http://www.theholidayspot.com/christmas/>

<http://www.bhg.com/holidays/christmas/>

<http://www.santas.net/aroundtheworld.htm>

<http://www.billybear4kids.com/holidays/christmas/christms.htm>

<http://www.northpole.com/>

<http://www.theholidayzone.com/christmas/>

<http://www.christmas-carols.net/>

<http://www.soon.org.uk/country/christmas.htm>